

# LEDJ

## **150W COB RGBA Par MKII** User Manual



Order code: LEDJ376

### WARNING

## FOR YOUR OWN SAFETY, PLEASE READ THIS USER MANUAL CAREFULLY BEFORE YOUR INITIAL START-UP!

- Before your initial start-up, please make sure that there is no damage caused during transportation.
- Should there be any damage, consult your dealer and do not use the equipment.
- To maintain the equipment in good working condition and to ensure safe operation, it is necessary for the user to follow the safety instructions and warning notes written in this manual.
- Please note that damages caused by user modifications to this equipment are not subject to warranty.



### IMPORTANT:

The manufacturer will not accept liability for any resulting damages caused by the non-observance of this manual or any unauthorised modification to the equipment.

- Never let the power cable come into contact with other cables. Handle the power cable and all mains voltage connections with particular caution!
- Never remove warning or informative labels from the unit.
- Do not open the equipment and do not modify the unit.
- Do not connect this equipment to a dimmer pack.
- Do not switch the equipment on and off in short intervals, as this will reduce the system's life.
- Only use the equipment indoors.
- Do not expose to flammable sources, liquids or gases.
- Always disconnect the power from the mains when equipment is not in use or before cleaning! Only handle the power-cable by the plug. Never pull out the plug by pulling the power-cable.
- Make sure that the available mains supply voltage is between 100~240V AC, 50/60Hz.
- Make sure that the power cable is never crimped or damaged. Check the equipment and the power cable periodically.
- If the equipment is dropped or damaged, disconnect the mains power supply immediately and have a qualified engineer inspect the equipment before operating again.
- If the equipment has been exposed to drastic temperature fluctuation (e.g. after transportation), do not connect power or switch it on immediately. The arising condensation might damage the equipment. Leave the equipment switched off until it has reached room temperature.
- If your product fails to function correctly, stop use immediately. Pack the unit securely (preferably in the original packing material), and return it to your Pro Light dealer for service.
- Only use fuses of same type and rating.
- Repairs, servicing and power connection must only be carried out by a qualified technician. THIS UNIT CONTAINS NO USER SERVICEABLE PARTS.
- This lighting fixture is for professional use only - it is not designed for or suitable for household use. The product must be installed by a qualified technician in accordance with local territory regulations. The safety of the installation is the responsibility of the installer. The fixture presents risks of severe injury or death due to fire hazards, electric shock and falls.
- Warning! Risk Group 2 LED product according to EN 62471. Do not view the light output with optical instruments or any device that may concentrate the beam.
- WARRANTY: One year from date of purchase.

### OPERATING DETERMINATIONS

If this equipment is operated in any other way, than those described in this manual, the product may suffer damage and the warranty becomes void. Incorrect operation may lead to danger e.g: short-circuit, burns and electric shocks etc.

Do not endanger your own safety and the safety of others!

Incorrect installation or use can cause serious damage to people and/or property.

### 150W COB RGBA Par MKII

The LEDJ 150W COB RGBA Par uses a COB LED to produce a high output wash with smooth colour mixing and no colour shadows. They feature an 80° beam angle and also come supplied with three beam reduction lenses (25°, 40° and 50°) which are easily interchangeable. The 4-button DMX display allows access of built-in colour macros, 4 selectable dimmer curves, 0-100% electronic dimming and selections of stand-alone, sound active and DMX modes.

- 1 x 150W quad-colour COB LED (RGBA)
- Beam angle: 80° native, 25°, 40° and 50° beam reduction lenses supplied
- 80° - 1,008 Lux @ 2m (full on)
- 1kHz refresh rate
- DMX channels: 2/4/5/6/7 or 10 selectable
- Auto, sound active and master/slave modes plus built-in programs
- 0-100% dimming and variable strobe
- Supplied with hanging bracket
- 4 push button menu with LED display
- PowerCON input/output
- 5-Pin XLR input/output
- 3-Pin XLR input/output
- Fan cooled



25° - Lux					
FULL ON	13100	3278	1460	820	525
R	3380	845	376	211	135
G	7200	1800	800	450	288
B	1310	328	146	82	52.5
A	2300	576	256	144	92.2

40° - Lux					
FULL ON	10800	2701	1200	675	432
R	2540	636	283	159	102
G	5920	1477	658	370	237
B	996	249	111	62.3	39.8
A	2000	501	223	125	80.2

50° - Lux					
FULL ON	6200	1550	689	388	248
R	1200	300	133	75	48
G	3260	816	363	204	131
B	600	150	66.7	37.5	24
A	1180	296	132	74	47.4

80° - Lux					
FULL ON	4040	1008	449	253	162
R	992	248	110	62	39.7
G	2070	517	230	129	82.7
B	344	86	38.2	21.5	13.8
A	732	183	81.3	45.8	29.3

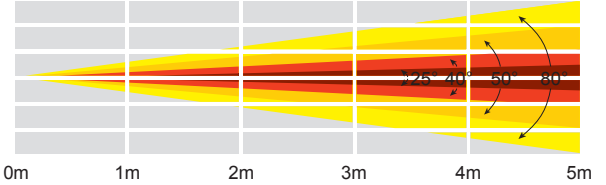

Specifications	150W COB RGBA Par
Power consumption	155W
Power supply	100~240V, 50/60Hz
Fuse	T3A 250V
Dimensions	312 x 220 x 270mm
Weight	4.2kg
Order code	LEDJ376

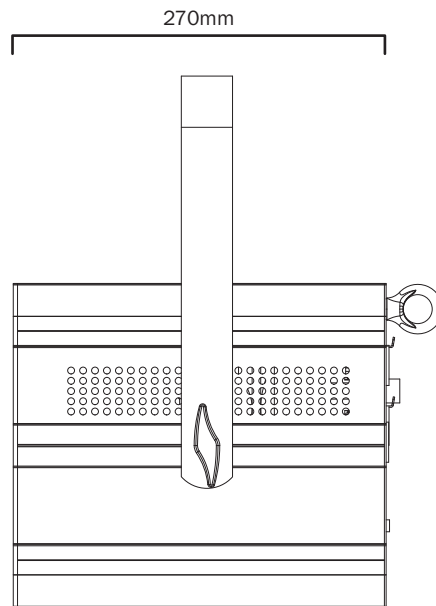
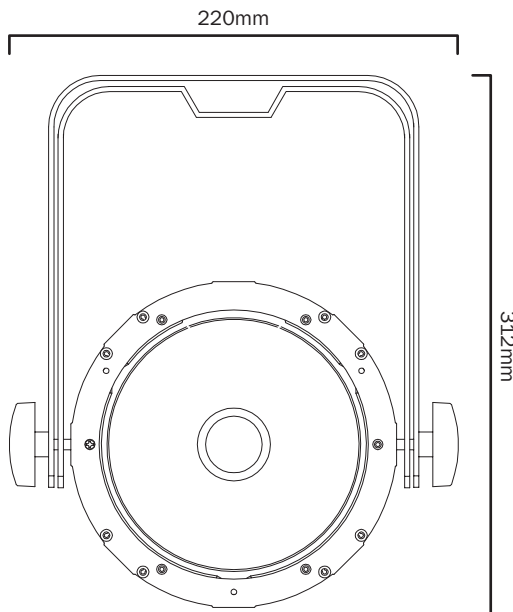

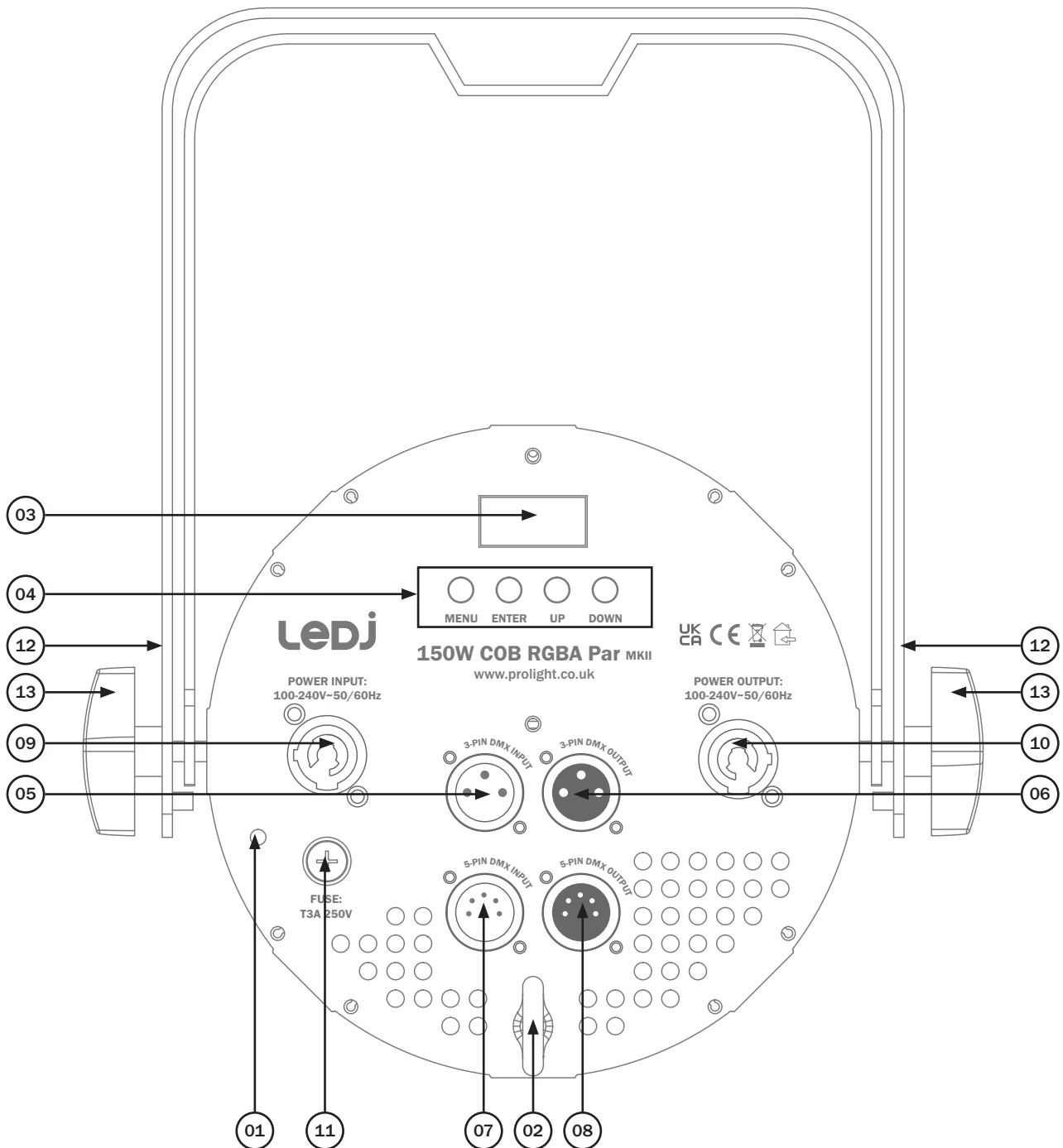

- 01 - Earth point
- 02 - Safety eye
- 03 - LED display
- 04 - Function buttons
- 05 - 3-Pin DMX input
- 06 - 3-Pin DMX output
- 07 - 5-Pin DMX input

- 08 - 5-Pin DMX output
- 09 - PowerCON input
- 10 - PowerCON output
- 11 - Fuse T3A 250V
- 12 - Hanging bracket
- 13 - Hanging bracket adjustable knob

In the box: **1 x fixture,**  
**1 x 25° beam reduction lens,**  
**1 x 40° beam reduction lens,**  
**1 x 50° beam reduction lens,**  
**1 x power cable**  
**& 1 x user manual**

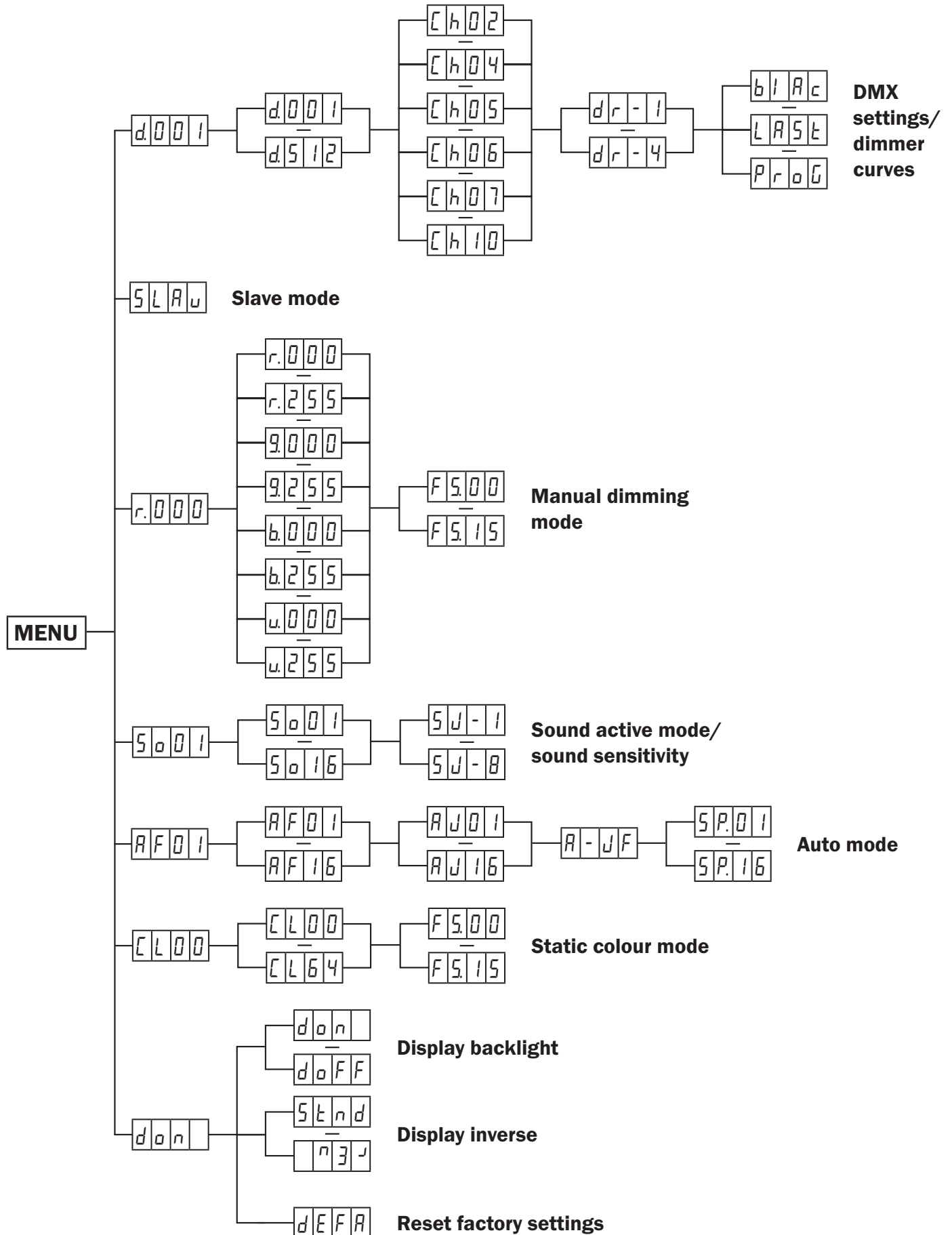

## DMX mode:

Operating in a DMX control mode environment gives the user the greatest flexibility when it comes to customising or creating a show. In this mode you will be able to control each individual trait of the fixture and each fixture independently.

To access the DMX address mode, press the “MENU” button on the rear of the unit to show *d00 1* on the LED display. Now use the “UP” and “DOWN” buttons to set the required DMX address. Press the “ENTER” button to confirm the setting. The DMX channel mode will now be displayed, use the “UP” and “DOWN” buttons on the rear of the unit to select either 2/4/5/6/7 or 10 DMX channel mode.

Press the “ENTER” button to confirm the setting. The dimming curve settings will now be displayed, use the “UP” and “DOWN” buttons on the rear of the unit to select between *dr - 1 ~ dr - 4*.

*dr - 1* - Linear      *dr - 2* - Square Law      *dr - 3* - Inverse Square Law      *dr - 4* - S-curve

Press the “ENTER” button to confirm the setting. Finally the DMX signal loss setting will be displayed, use the “UP” and “DOWN” buttons on the rear of the unit to select between *bl Ac* (blackout), *LAST* (holds last command) or *Prog* (auto programs).

Press the “ENTER” button to confirm the setting.

To exit out of any of the above options, press the “MENU” button.

## 2 channel mode:

Channel	Value	Function
1	000	No function
	001-255	Halogen emulation 1800K-3200K
2	000-255	Master dimmer (0-100%)

## 4 channel mode:

Channel	Value	Function
1	000-255	Colour macros (see page 9)
2	000-031	LED off
	032-063	LED on
	064-095	Strobe (slow-fast)
	096-127	LED on
	128-159	Strobe pulse (slow-fast)
	160-191	LED on
	192-223	Strobe random (slow-fast)
	224-255	LED on
3	000-255	Master dimmer (0-100%)
4	000-020	Linear (dimming curve)
	021-040	Square Law (dimming curve)
	041-060	Inverse Square Law (dimming curve)
	061-080	S-Curve (dimming curve)
	081-255	Default dimming curve (set via menu)

## 5 channel mode:

Channel	Value	Function
1	000-255	Red dimmer (0-100%)
2	000-255	Green dimmer (0-100%)
3	000-255	Blue dimmer (0-100%)
4	000-255	Amber dimmer (0-100%)
5	000-020	Linear (dimming curve)
	021-040	Square Law (dimming curve)
	041-060	Inverse Square Law (dimming curve)
	061-080	S-Curve (dimming curve)
	081-255	Default dimming curve (set via menu)

## 6 channel mode:

Channel	Value	Function
1	000-255	Red dimmer (0-100%)
2	000-255	Green dimmer (0-100%)
3	000-255	Blue dimmer (0-100%)
4	000-255	Amber dimmer (0-100%)
5	000-255	Master dimmer (0-100%)
6	000-020	Linear (dimming curve)
	021-040	Square Law (dimming curve)
	041-060	Inverse Square Law (dimming curve)
	061-080	S-Curve (dimming curve)
	081-255	Default dimming curve (set via menu)

### 7 channel mode:

Channel	Value	Function
1	000-255	Red dimmer (0-100%)
2	000-255	Green dimmer (0-100%)
3	000-255	Blue dimmer (0-100%)
4	000-255	Amber dimmer (0-100%)
5	000-031	LED off
	032-063	LED on
	064-095	Strobe (slow-fast)
	096-127	LED on
	128-159	Strobe pulse (slow-fast)
	160-191	LED on
	192-223	Strobe random (slow-fast)
	224-255	LED on
6	000-255	Master dimmer (0-100%)
7	000-020	Linear (dimming curve)
	021-040	Square Law (dimming curve)
	041-060	Inverse Square Law (dimming curve)
	061-080	S-Curve (dimming curve)
	081-255	Default dimming curve (set via menu)

### 10 channel mode:

Channel	Value	Function
1	000-255	Red dimmer (0-100%)
2	000-255	Green dimmer (0-100%)
3	000-255	Blue dimmer (0-100%)
4	000-255	Amber dimmer (0-100%)
5	000-031	LED off
	032-063	LED on
	064-095	Strobe (slow-fast)
	096-127	LED on
	128-159	Strobe pulse (slow-fast)
	160-191	LED on
	192-223	Strobe random (slow-fast)
	224-255	LED on
6	000-255	Master dimmer (0-100%)
7	000-051	Dimming mode (CH1-CH6)
	052-102	Colour macro mode (CH8 value 000-255)
	103-153	Colour change mode
	154-204	Colour fade mode
	205-255	Sound active mode
8	000-015	Colour Change 1 Colour Fade 1 Sound Active 1
	016-031	Colour Change 2 Colour Fade 2 Sound Active 2
	032-047	Colour Change 3 Colour Fade 3 Sound Active 3
	048-063	Colour Change 4 Colour Fade 4 Sound Active 4
	064-079	Colour Change 5 Colour Fade 5 Sound Active 5
	080-095	Colour Change 6 Colour Fade 6 Sound Active 6
	096-111	Colour Change 7 Colour Fade 7 Sound Active 7
	112-127	Colour Change 8 Colour Fade 8 Sound Active 8

Colour macros (see page 9 for values)

Channel	Value	Function
8 cont.	128-143	Colour Change 9 Colour Fade 9 Sound Active 9
	144-159	Colour Change 10 Colour Fade 10 Sound Active 10
	160-175	Colour Change 11 Colour Fade 11 Sound Active 11
	176-191	Colour Change 12 Colour Fade 12 Sound Active 12
	192-207	Colour Change 13 Colour Fade 13 Sound Active 13
	208-223	Colour Change 14 Colour Fade 14 Sound Active 14
	224-239	Colour Change 15 Colour Fade 15 Sound Active 15
	240-255	Colour Change 16 Colour Fade 16 Sound Active 16
9	000-255	No function (CH7 value 000-102)
		Speed (slow-fast) (CH7 value 103-204)
		Sensitivity (low-high) (CH7 value 205-255)
10	000-020	Linear (dimming curve)
	021-040	Square Law (dimming curve)
	041-060	Inverse Square Law (dimming curve)
	061-080	S-Curve (dimming curve)
	081-255	Default dimming curve (set via menu)

Colour macros (see page 9 for values)



### Colour macros:

Value	Function
000	No function
001-004	Colour 1
005-008	Colour 2
009-012	Colour 3
012-016	Colour 4
017-020	Colour 5
021-024	Colour 6
025-028	Colour 7
029-032	Colour 8
033-036	Colour 9
037-040	Colour 10
041-044	Colour 11
045-048	Colour 12
049-052	Colour 13
053-056	Colour 14
057-060	Colour 15
061-064	Colour 16
065-068	Colour 17
069-072	Colour 18
073-076	Colour 19
077-080	Colour 20

081-084	Colour 21
085-088	Colour 22
089-092	Colour 23
093-096	Colour 24
097-100	Colour 25
101-104	Colour 26
105-108	Colour 27
109-112	Colour 28
113-116	Colour 29
117-120	Colour 30
121-124	Colour 31
125-128	Colour 32
129-132	Colour 33
133-136	Colour 34
137-140	Colour 35
141-144	Colour 36
145-148	Colour 37
149-152	Colour 38
153-156	Colour 39
157-160	Colour 40
161-164	Colour 41
165-168	Colour 42

169-172	Colour 43
173-176	Colour 44
177-180	Colour 45
181-184	Colour 46
185-188	Colour 47
189-192	Colour 48
193-196	Colour 49
197-200	Colour 50
201-204	Colour 51
205-208	Colour 52
209-212	Colour 53
213-216	Colour 54
217-220	Colour 55
221-224	Colour 56
225-228	Colour 57
229-232	Colour 58
233-236	Colour 59
237-240	Colour 60
241-244	Colour 61
245-248	Colour 62
249-252	Colour 63
253-255	Colour 64

### Master/slave mode:

To set the master unit, press the “MENU” button on the rear of the master unit then select your desired program (sound active or dimmer modes). To set the other units in slave mode, press the “MENU” button on the rear of the unit to show *SLAV* on the LED display and press the “ENTER” button to confirm the setting. The units will now run in sequence with the master unit.

To exit out of any of the above options, press the “MENU” button.

Please ensure that all slave units are set to the same DMX channel mode as the master unit.

### Manual dimming mode:

To access the manual dimming mode, press the “MENU” button until the display shows *r.255* on the LED display. Use the “UP” and “DOWN” buttons to select the required brightness of red from *r.000* ~ *r.255*. Press the “ENTER” button and repeat for *g* (green), *b* (blue) and *u* (amber). Once all colours have been set you can then adjust the flash speed by pressing the “ENTER” button and then use the “UP” and “DOWN” buttons to select any value from *F5.00* ~ *F5.15*.

Press the “ENTER” button to confirm the setting.

**Value: 000 - 255 (000 = low brightness, 255 = high brightness)**

**Value: 00 - 15 (00 = no flash, 15 = fast flash speed)**

To exit out of any of the above options, press the “MENU” button.

### Sound active mode:

To access the sound active mode, press the “MENU” button until the display shows *5001* on the LED display. Use the “UP” and “DOWN” buttons to select the required sound mode from *5001* ~ *5016*.

To adjust the sound sensitivity press the “ENTER” button and then use the “UP” and “DOWN” buttons to select any value from *5J-1* ~ *5J-8*. Press the “ENTER” button to confirm the setting.

**Value: 1 - 8 (1 = low sensitivity, 8 = high sensitivity)**

To exit out of any of the above options, press the “MENU” button.

### Auto mode:

To access the auto mode, press the “MENU” button until the display shows *AF01* on the LED display. Firstly the program speed needs to be set. To adjust the speed, press the “ENTER” button until *SP.01* is displayed on the rear of the unit. Then use the “UP” and “DOWN” buttons to select any value from *SP.01* ~ *SP.16*. Press the “ENTER” button and the unit will start the auto fade/change mode *A-JF*.

Alternatively by pressing the “ENTER” button once more and use the “UP” and “DOWN” buttons you are able to select the required auto fade mode from *AF01* ~ *AF16*. By pressing the “ENTER” button a third time and using the “UP” and “DOWN” buttons you are able to select the required auto change mode from *AJ01* ~ *AJ16*. Press the “ENTER” button to confirm the setting.

**Value: 01 - 16 (01 = slow speed, 16 = fast speed)**

To exit out of any of the above options, press the “MENU” button.

### Static colour:

To access the static colour mode, press the “MENU” button until the display shows *CL00* on the LED display. Use the “UP” and “DOWN” buttons to select the required static colour from *CL00 ~ CL64*. To adjust the flash speed press the “ENTER” button and then use the “UP” and “DOWN” buttons to select any value from *F5.00 ~ F5.15*. Press the “ENTER” button to confirm the setting.

**Value: 00 - 15 (00 = no flash, 15 = fast flash speed)**

To exit out of any of the above options, press the “MENU” button.

### Display backlight:

To access the display backlight setting, press the “MENU” button until the display shows *don* on the LED display. Use the “UP” and “DOWN” buttons to select either *don* (display backlight on) ~ *doff* (display backlight off). Press the “ENTER” button to confirm the setting.

To exit out of any of the above options, press the “MENU” button.

### Display inverse:

To access the display inverse setting, press the “MENU” button until the display shows *don* on the LED display. Press the “ENTER” button to display *stnd* and use the “UP” and “DOWN” buttons to select either *stnd* (display standard) ~ *inv* (display inverse).

Press the “ENTER” button to confirm the setting.

To exit out of any of the above options, press the “MENU” button.

### Reset factory settings:

To reset the factory settings, press the “MENU” button until the display shows *don* on the LED display. Press the “ENTER” button twice to display *defr*. Press the “UP” and “DOWN” buttons together and the fixture will be reset to its factory settings.

To exit out of any of the above options, press the “MENU” button.

### Setting the DMX address:

The DMX mode enables the use of a universal DMX controller. Each fixture requires a “start address” from 1- 511. A fixture requiring one or more channels for control begins to read the data on the channel indicated by the start address. For example, a fixture that occupies or uses 7 channels of DMX and was addressed to start on DMX channel 100, would read data from channels: 100,101,102,103,104,105 and 106. Choose a start address so that the channels used do not overlap. E.g. the next unit in the chain starts at 107.

### DMX 512:

DMX (Digital Multiplex) is a universal protocol used as a form of communication between intelligent fixtures and controllers. A DMX controller sends DMX data instructions from the controller to the fixture. DMX data is sent as serial data that travels from fixture to fixture via the DATA “IN” and DATA “OUT” XLR terminals located on all DMX fixtures (most controllers only have a data “out” terminal).

### DMX linking:

DMX is a language allowing all makes and models of different manufactures to be linked together and operate from a single controller, as long as all fixtures and the controller are DMX compliant. To ensure proper DMX data transmission, when using several DMX fixtures try to use the shortest cable path possible. The order in which fixtures are connected in a DMX line does not influence the DMX addressing. For example; a fixture assigned to a DMX address of 1 may be placed anywhere in a DMX line, at the beginning, at the end, or anywhere in the middle. When a fixture is assigned a DMX address of 1, the DMX controller knows to send DATA assigned to address 1 to that unit, no matter where it is located in the DMX chain.

### DATA cable (DMX cable) requirements (for DMX operation):

This fixture can be controlled via DMX-512 protocol. The DMX address is set on the back of the unit. Your unit and your DMX controller require a standard 3-pin XLR connector for data input/output, see image below.



Further DMX cables can be purchased from all good sound and lighting suppliers or Pro Light Concepts dealers.

Please quote:

**CABL10 – 2m**

**CABL11 – 5m**

**CABL12 – 10m**

**Note: DMX cable must be daisy chained and cannot be split.**

**Notice:**

Be sure to follow the diagrams below when making your own cables. Do not connect the cables shield conductor to the ground lug or allow the shield conductor to come in contact with the XLRs outer casing. Grounding the shield could cause a short circuit and erratic behaviour.

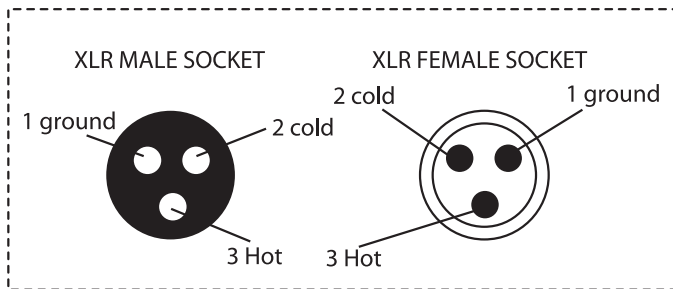
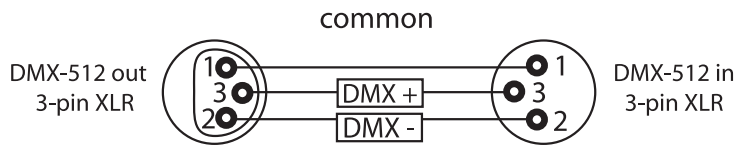

XLR Pin Configuration
Pin 1 = Ground
Pin 2 = Negative
Pin 3 = Postive

**Special note:**

**Line termination:**

When longer runs of cable are used, you may need to use a terminator on the last unit to avoid erratic behaviour.

**Using a cable terminator will decrease the possibilities of erratic behaviour.**

**(3-pin - Order ref: CABL90, 5-pin - Order ref: CABL89)**

Termination reduces signal transmission problems and interference. It is always advisable to connect a DMX terminal, (resistance 120 Ohm 1/4 W) between pin 2 (DMX-) and pin 3 (DMX+) of the last fixture.

**5-pin XLR DMX connectors:**

Some manufactures use 5-pin XLR connectors for data transmission in place of 3-pin. 5-pin XLR fixtures may be implemented in a 3-pin XLR DMX line. When inserting standard 5-pin XLR connectors in to a 3-pin line a cable adaptor must be used. The diagram below details the correct cable conversion.

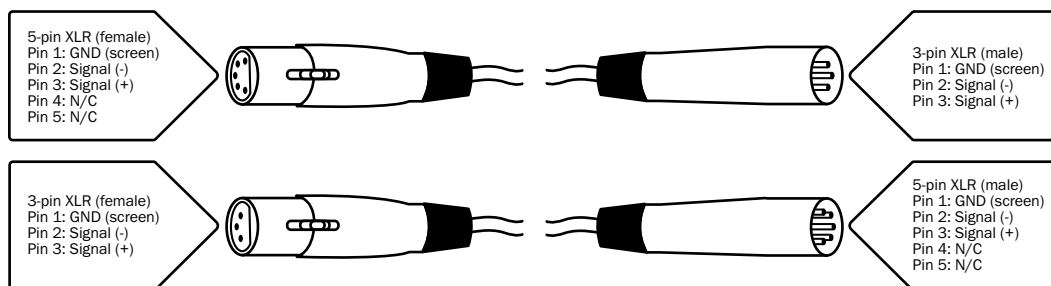



***Correct Disposal of this Product  
(Waste Electrical & Electronic Equipment)***

**(Applicable in the European Union and other European countries  
with separate collection systems)**

This marking shown on the product or its literature, indicates that it should not be disposed with other household wastes at the end of its working life. To prevent possible harm to the environment or human health from uncontrolled waste disposal, please separate this from other types of wastes and recycle it responsibly to promote the sustainable reuse of material resources.

Household users should contact either the retailer where they purchased this product, or their local government office, for details of where and how they can take this item for environmentally safe recycling.

Business users should contact their supplier and check the terms and conditions of the purchase contract. This product should not be mixed with other commercial wastes for disposal.





**LEDj**